



# 2YM15 Series

Configuration	4-stroke, vertical, water-cooled diesel engine		
Maximum output at crankshaft	* 10.0 kW@3600 rpm	[13.6 mhp@3600 rpm]	
Displacement	0.570 L	[34.7 cu in]	
Bore x stroke	70 mm x 74 mm	[2.75 in x 2.91 in]	
Cylinders	In-line		
Combustion system	Indirect injection		
Aspiration	Natural aspiration		
Starting system	Electric starting 12V - 1.4 kW		
Alternator	12V - 125A		
Cooling system	Fresh water cooling with heat exchanger		
Lubrication system	Enclosed, forced lubricating system		
Direction of rotation [crankshaft]	Counterclockwise viewed from stern		
Dry weight without gear	103 kg	[227 lbs]	
Emission compliance	EU: RCD 2	BSO II	EMC
	US: EPA Tier 3		
Engine mounting	Rubber type flexible mounting		

**NOTE:**Fuel condition: Density at 15°C = 0.84 g/cm<sup>3</sup>; 1 kW = 1.3596 mhp = 1.3410 HP

\* Fuel temperature 40°C at the inlet of the fuel injection pump [ISO 8665: 2006]

Technical data is according to ISO 8665: 2006/3046-1

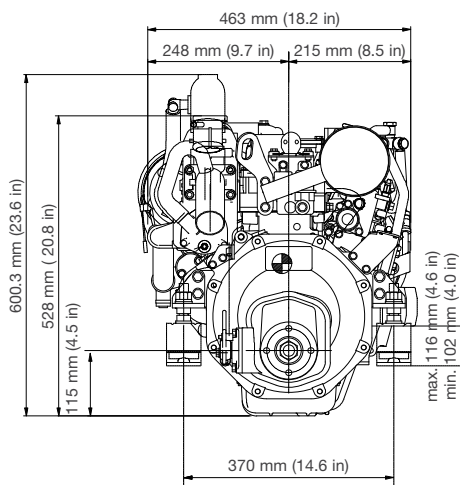
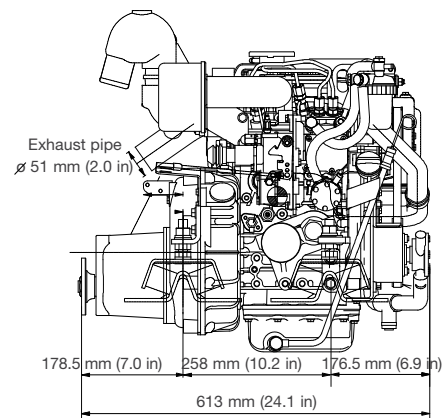
**DIMENSIONS****Rear view****Right side view**

2YM15 with KM2P-1 marine gear



PERFORMANCE CURVES

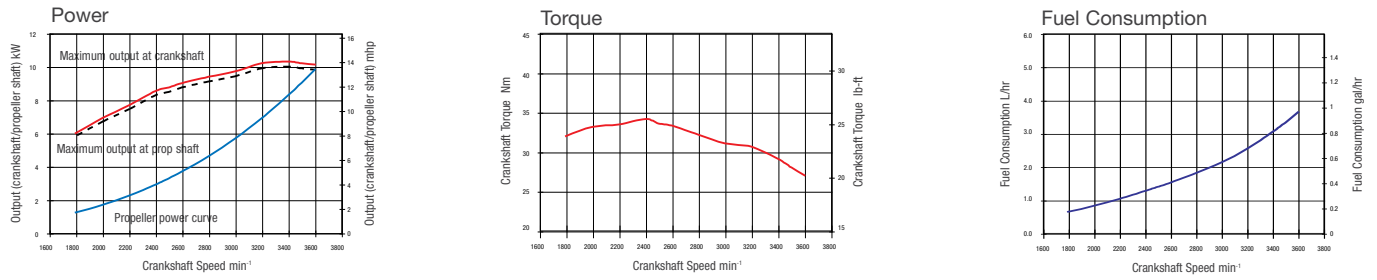

MARINE GEARS / DRIVE\*

Model	KM2P-1 (parallel)			Saildrive [SD25]
Type	Mechanical cone clutch			Constant mesh gear with dog clutch
Dry weight	9.8 kg [22 lbs]			30 kg [66 lbs]
Reduction Ratio [fwd/rev]	2.21/3.06	2.62/3.06	3.22/3.06	2.64/2.64
Propeller speed [fwd/rev]	1629/1176	1374/1176	1118/1176	1363/1363
Direction of rotation (viewed from stern)	Clockwise			Counterclockwise
Dry weight - engine & gear	113 kg [249 lbs]			134 kg [295 lbs]
Length engine and gear/drive	613 mm [24 in]			793 mm [31 in]

\* Other marine gearboxes and configurations available upon request. Contact your local supplier for more information.

INSTRUMENT PANELS

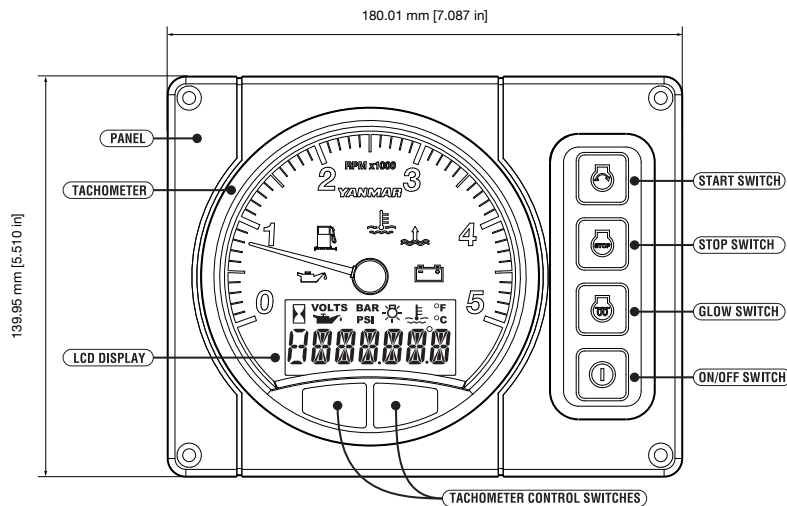

B20-panel

ACCESSORIES

**Standard engine package**

- Set of flexible mounts
- Exhaust mixing elbow [L-type]
- Belt safety cover
- Expansion tank for fresh water cooling system
- Alternator 12V - 125A
- Electric stop solenoid
- Operation manual
- Sensor for instrument panel
- B20-panel

**Optional accessories**

- Extension wire harness [4m, 6m, 10m]
- High-riser mixing elbow [instead of L-elbow]
- Hot water kit with cocks
- Dual Harness (For 2nd Station)
- Propeller cone nut kit SD25

NOTE: All data subject to change without notice. Text and illustrations are not binding.