



4JH110 Common Rail Series

Configuration	4-stroke, vertical, water-cooled diesel engine		
Maximum output at crankshaft	* 80.9 kW@3200 rpm	[110 mhp@3200 rpm]	
Displacement	2.000 L	[122 cu in]	
Bore x stroke	84 mm x 90 mm	[3.31 in x 3.54 in]	
Cylinders	In-line		
Combustion system	Direct injection with Bosch common-rail system		
Aspiration	Turbocharged with intercooler		
Starting system	Electric starting 12V - 1.4 kW		
Alternator	12V - 125A		
Cooling system	Fresh water cooling by centrifugal water pump and rubber impeller sea water pump		
Lubrication system	Enclosed, forced lubricating system		
Direction of rotation [crankshaft]	Counterclockwise viewed from stern		
Dry weight without gear	229 kg	[505 lbs]	
Emission compliance	EU: RCD 2	BSO II	EMC
	US: EPA Tier 3		
Engine mounting	Rubber type flexible mounting		

NOTE:

Fuel condition: Density at 15°C = 0.84 g/cm³: 1 kW = 1.3596 mhp = 1.3410 HP
 * Fuel temperature 40°C at the inlet of the fuel injection pump [ISO 8665: 2006]
 Technical data is according to ISO 8665: 2006

DIMENSIONS

Rear view

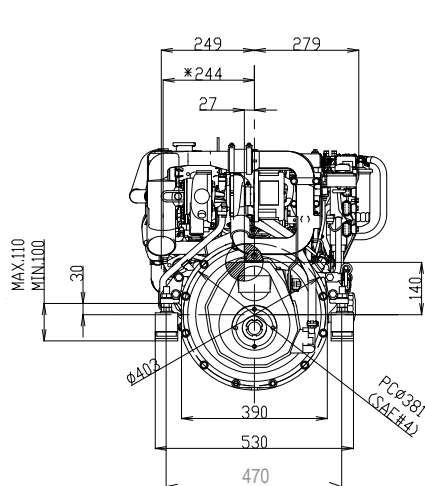

Right side view

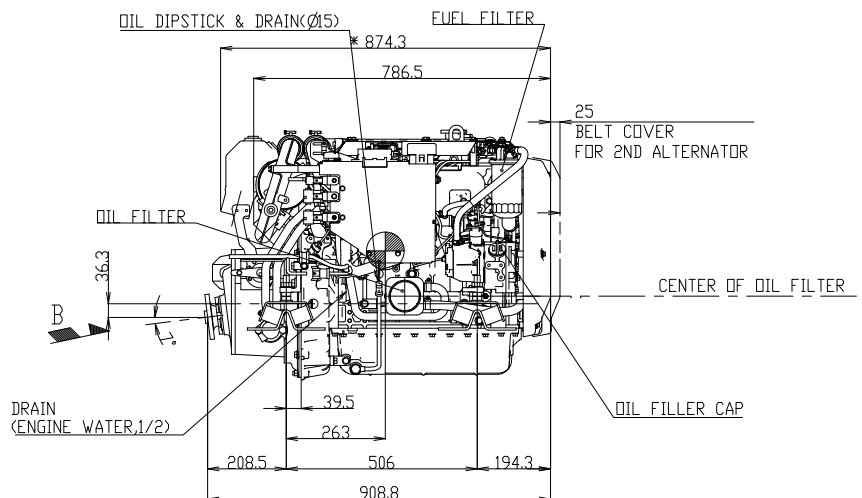

4JH110 with KM4A2 marine gear



PERFORMANCE CURVES

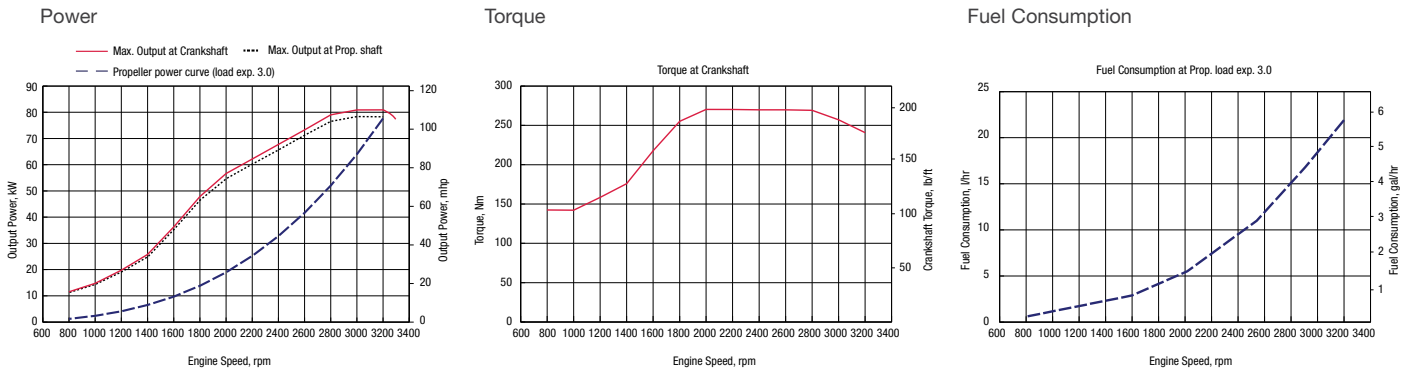

MARINE GEARS*

Model	KM4A [down angle: 8°]		ZF25A [down angle: 8°]		KM4A2 [down angle: 7°]			ZF30M	
Type	Hydraulic, multi disk clutch		Hydraulic, multi disk clutch		Mechanical cone clutch			Mechanical multi-disc	
Dry weight**	30 kg [66 lbs]		24 kg [53 lbs]		28.5 kg [63 lbs]			28 kg [62 lbs]	
Reduction Ratio [fwd/rev]	2.04/2.04	2.45/2.45	1.93/1.93	2.48/2.48	1.47/1.47	2.14 / 2.14	2.63/2.63	2.15/2.64	2.70/2.64
Propeller speed [fwd/rev]	1569/1569	1306/1306	1658/1658	1290/1290	2177/2175	1495/1494	1217/1216	1488/1212	1185/1212
Direction of rotation (viewed from stern)	Clockwise & counterclockwise		Clockwise & counterclockwise		Clockwise & counterclockwise			Clockwise	
Dry weight - engine & gear**	259 kg [571 lbs]		253 kg [558 lbs]		257.5 kg [568 lbs]			256 kg [564 lbs]	
Length engine and gear/drive	907 mm [35.7 in]		905 mm [35.6 in]		909 mm [35.8 in]			925 mm [36.4 in]	

* Other marine gearboxes and configurations available upon request. Contact your local supplier for more information.

** Dry weight includes cooler, brackets and damper disk.

INSTRUMENT PANELS

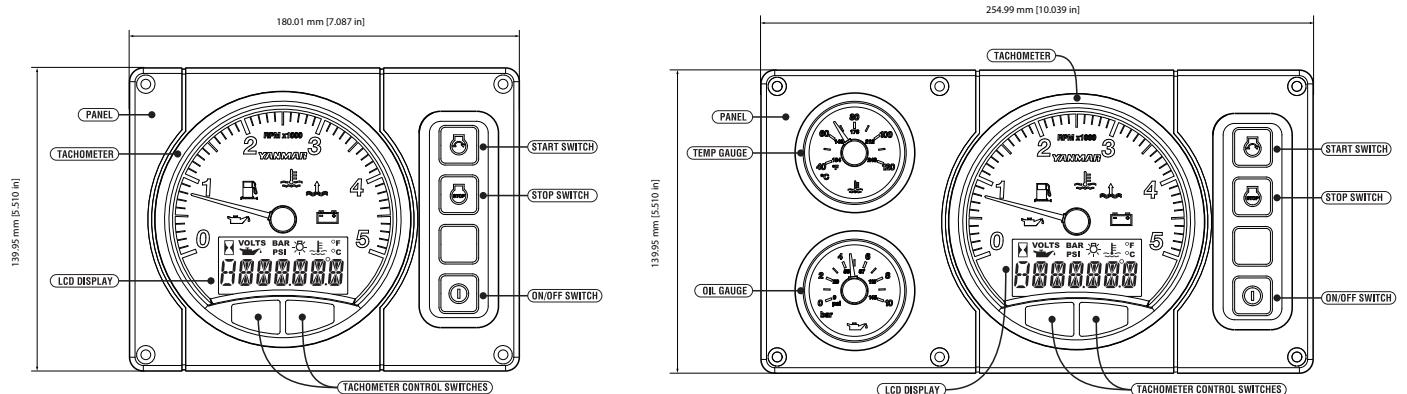

B25-panel

C35-panel

ACCESSORIES

Standard engine package

- Set of flexible engine mounts
- Exhaust mixing elbow [L-type]
- Belt safety cover
- Fresh water expansion tank
- Alternator 12V - 125A
- Operation manual
- B25-panel
- Sensors for instrument panel
- Seawaterpump front mounted
- Engine Topcover for protection
- Emergency stop switch

Optional accessories

- Second alternator 12V - 125A or 24V - 60A
- High-riser mixing elbow [instead of L-elbow]
- Extension wire harness [3m, 5m, 10m]
- Hot water kit with cocks
- Dual Harness (For 2nd Station)
- C35-panel
- Oil pressure sensor for C35-panel
- Extension saildrive leg [75 mm]
- NMEA 2000 convertor for Engine monitory system

NOTE: All data subject to change without notice. Text and illustrations are not binding.